

Inhale the Atmosphere / Contradiction

♩ = 105

Voice

You can smell it in the

Guitar tuning:
C G C F A D

Electric Guitar 1

4

Vo.

air: cold wind is start-ing to blow -

El. Guit. 1

8

Vo.

So live while you still can but

El. Guit. 1

11

Vo.

don't for - get the re - al - i - ty of man-kind's

El. Guit. 1

15

Vo.

fall turn - ing to wint-er, e - tern - al

El. Guit. 1

19

Vo.
 dark - ness and night.

El. Guit. 1

25

Vo.
 All land - scapes are feel - ing it - :

El. Guit. 1

El. B.

Bass tuning:
C G C F

29

Vo.
 they shall be pur - i - fied - .

El. Guit. 1

El. B.

33

Vo.
 Li-ber-a - tion from our vici - ous yoke

El. Guit. 1

El. B.

37

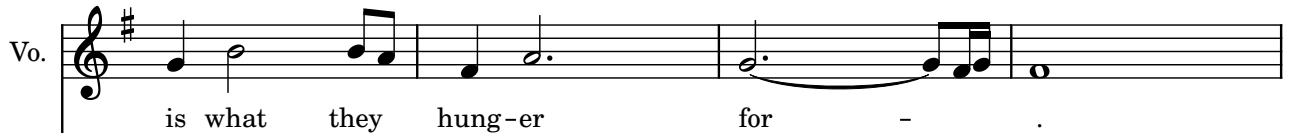
Vo. 

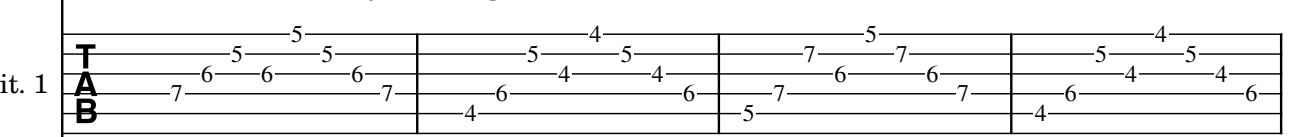
El. Guit. 1 

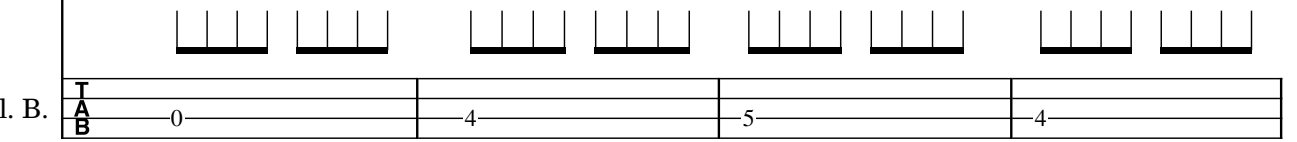
El. B. 

41

Vo. 

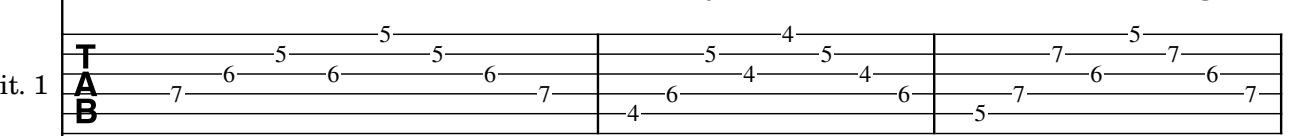
El. Guit. 1 

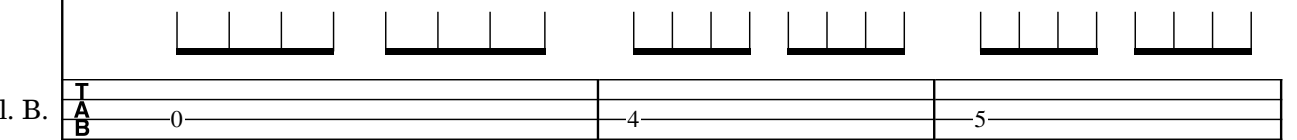
El. B. 

44

♩ = 170

Vo. 

El. Guit. 1 

Guitar tuning:
CGCFAD

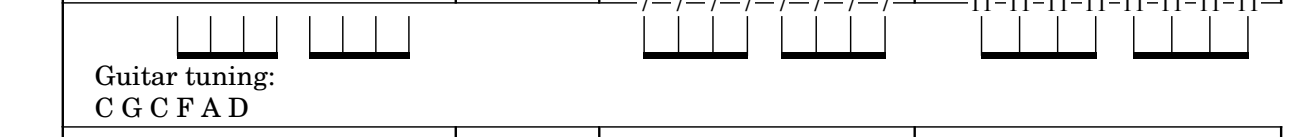
El. Guit. 2 

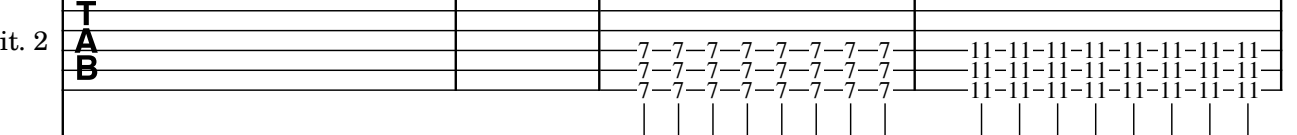
El. B. 

48

Vo.

new be - gin - ing - , it is E - den, a

El. Guit. 1
TAB 12-12-12-12-12-12-12-12 14-14-14-14-14-14-14-14 7-7-7-7-7-7-7-7-7-7-7-7-7-7-7-7-7-7
12-12-12-12-12-12-12-12 14-14-14-14-14-14-14-14 7-7-7-7-7-7-7-7-7-7-7-7-7-7-7-7-7-7
12-12-12-12-12-12-12-12 14-14-14-14-14-14-14-14 7-7-7-7-7-7-7-7-7-7-7-7-7-7-7-7-7-7

El. Guit. 2
TAB 12-12-12-12-12-12-12-12 14-14-14-14-14-14-14-14 7-7-7-7-7-7-7-7-7-7-7-7-7-7-7-7-7-7
12-12-12-12-12-12-12-12 14-14-14-14-14-14-14-14 7-7-7-7-7-7-7-7-7-7-7-7-7-7-7-7-7-7
12-12-12-12-12-12-12-12 14-14-14-14-14-14-14-14 7-7-7-7-7-7-7-7-7-7-7-7-7-7-7-7-7-7

El. B.
TAB 5-5-5-5-5-5-5-5 7-7-7-7-7-7-7-7 0-0-0-0-0-0-0-0

51

Vo.

pa - ra - dise on Earth - - -

El. Guit. 1
TAB 11-11-11-11-11-11-11-11 11-11-11-11-11-11 12-12-12-12-12-12-12-12 12-12-12-12-12-12-12-12
11-11-11-11-11-11-11-11 11-11-11-11-11-11 12-12-12-12-12-12-12-12 12-12-12-12-12-12-12-12
11-11-11-11-11-11-11-11 11-11-11-11-11-11 12-12-12-12-12-12-12-12 12-12-12-12-12-12-12-12

El. Guit. 2
TAB 11-11-11-11-11-11-11-11 11-11-11-11-11-11 12-12-12-12-12-12-12-12 12-12-12-12-12-12-12-12
11-11-11-11-11-11-11-11 11-11-11-11-11-11 12-12-12-12-12-12-12-12 12-12-12-12-12-12-12-12
11-11-11-11-11-11-11-11 11-11-11-11-11-11 12-12-12-12-12-12-12-12 12-12-12-12-12-12-12-12

El. B.
TAB 4-4-4-4-4-4-4-4 5-5-5-5-5-5-5-5

53

Vo.

- - , the pu - rest form of

El. Guit. 1
TAB 14-14-14-14-14-14-14-14 7 11
14-14-14-14-14-14-14-14 7 11
14-14-14-14-14-14-14-14 7 11

El. Guit. 2
TAB 14-14-14-14-14-14-14-14 7 11
14-14-14-14-14-14-14-14 7 11
14-14-14-14-14-14-14-14 7 11

El. B.
TAB 7-7-7-7-7-7-7-7 0-0-0-0-0-0-0-0 4-4-4-4-4-4-4-4

56

Vo.

El. Guit. 1
 TAB 12 14 7 11
 12 14 7 11
 12 14 7 11

El. Guit. 2
 TAB 12 14 7 11
 12 14 7 11
 12 14 7 11

El. B.
 TAB 5-5-5-5-5-5-5-5 7-7-7-7-7-7-7-7 0-0-0-0-0-0-0-0 4-4-4-4-4-4-4-4

60

rit.

Vo.

El. Guit. 1
 TAB 12 14 7 11
 12 14 7 11
 12 14 7 11

El. Guit. 2
 TAB 12 14 7 11
 12 14 7 11
 12 14 7 11

El. B.
 TAB 5-5-5-5-5-5-5-5 7-7-7-7-7-7-7-7 0 4

64

$\text{♩} = 105$

Vo.

El. Guit. 1
 TAB 12 14 7 5 5-9 9-5-5 5 5-9 9-5-5
 12 14 7 5 5-9 9-5-5 5 5-9 9-5-5

N.H.

El. Guit. 2
 TAB 12 14 7
 12 14 7

El. B.
 TAB 5 7 0

71

rit.



♩ = 90

El. Guit. 1

71-76: El. Guit. 1 TAB. Measure 71: 12-12-12 (top), 5 (bottom). Measure 72: 4-3-4-5 (top), 5 (bottom). Measure 73: 6/8 time signature, 0-0-0-0-0-0 (top), 3-2-0-0 (bottom). Measure 74: N.H. (top), N.H. (bottom). Measure 75: P.M. (top), P.M. (bottom). Measure 76: P.M. (top), P.M. (bottom).

El. Guit. 1

77-79: El. Guit. 1 TAB. Measure 77: 0-0-0-0-0-0 (top), 3-2-0-0 (bottom). Measure 78: 0-0-0-0-0-0 (top), 3-2-0-0 (bottom). Measure 79: 0-0-0-0-0-0 (top), 3-2-0-0 (bottom). Measure 80: P.M. (top), P.M. (bottom).

El. Guit. 1

81-82: El. Guit. 1 TAB. Measure 81: 5-5-5-5-5-3 (top), 3-3-3-3 (bottom). Measure 82: 3-3-3-3-3-2 (top), 2-2-2-2 (bottom). Measure 83: 0-0-0-0-0-0 (top), 3-2-0-0 (bottom). Measure 84: P.M. (top), P.M. (bottom).

El. Guit. 2

81-82: El. Guit. 2 TAB. Measure 81: 3-3-3-3-3-2 (top), 2-2-2-2 (bottom). Measure 82: 2-2-2-2-2-0 (top), 0-0-0-0 (bottom). Measure 83: 0-0-0-0-0-0 (top), 3-2-0-0 (bottom). Measure 84: P.M. (top), P.M. (bottom).

El. Guit. 1

85-86: El. Guit. 1 TAB. Measure 85: 0-0-0-0-0-0 (top), 3-2-0-0 (bottom). Measure 86: 0-0-0-0-0-0 (top), 3-2-0-0 (bottom). Measure 87: 0-0-0-0-0-0 (top), 3-2-0-0 (bottom). Measure 88: P.M. (top), P.M. (bottom).

El. Guit. 2

85-86: El. Guit. 2 TAB. Measure 85: 0-0-0-0-0-0 (top), 3-2-0-0 (bottom). Measure 86: 0-0-0-0-0-0 (top), 3-2-0-0 (bottom). Measure 87: 0-0-0-0-0-0 (top), 3-2-0-0 (bottom). Measure 88: P.M. (top), P.M. (bottom).

Vo.

86-88: Vocal line in B-flat major. Measure 86: whole rest. Measure 87: whole rest. Measure 88: The es - sence

El. Guit. 1

89-90: El. Guit. 1 TAB. Measure 89: 5-5-5-5-5-3 (top), 3-3-3-3 (bottom). Measure 90: 3-3-3-3-3-2 (top), 2-2-2-2 (bottom). Measure 91: 0-0-0-0-0-0 (top), 0-0-0-0 (bottom). Measure 92: P.M. (top), P.M. (bottom).

El. Guit. 2

89-90: El. Guit. 2 TAB. Measure 89: 3-3-3-3-3-2 (top), 2-2-2-2 (bottom). Measure 90: 2-2-2-2-2-0 (top), 0-0-0-0 (bottom). Measure 91: 0-0-0-0-0-0 (top), 0-0-0-0 (bottom). Measure 92: P.M. (top), P.M. (bottom).

El. B.

91-92: El. B. TAB. Measure 91: 0-0-0-0-0-0 (top), 0-0-0-0 (bottom). Measure 92: 0-0-0-0-0-0 (top), 0-0-0-0 (bottom).

89

Vo.

of e - vil is in us all,

El. Guit. 1
T A B
2 2 2 2 2 3 3 3 3 3 5 5 5 5 5 5 3 3 3 3 3 2 2 2 2 2
3 3 3 3 3 3 3 3 3 3 5 5 5 5 5 5 3 3 3 3 3 3 3 3 3 3
2 2 2 2 2 3 3 3 3 3 5 5 5 5 5 5 3 3 3 3 3 2 2 3 2 2

El. Guit. 2
T A B
2 2 2 2 2 3 3 3 3 3 5 5 5 5 5 5 3 3 3 3 3 2 2 2 2 2
3 3 3 3 3 3 3 3 3 3 5 5 5 5 5 5 3 3 3 3 3 3 3 3 3 3
2 2 2 2 2 3 3 3 3 3 5 5 5 5 5 5 3 3 3 3 3 2 2 3 2 2

El. B.
T A B
2 2 2 2 2 3 3 3 3 3 5 5 5 5 5 5 3 3 3 3 3 2 2 3 2 2

92

Vo.

the e-go-is - tic and greedy, po-wer-lust-ing self.

El. Guit. 1
T A B
0 0 0 0 0 0 0 0 0 0 2 2 2 2 2 3 3 3 3 3 5 5 5 5 5 5 0 0 0 0 0
0 0 0 0 0 0 0 0 0 0 3 3 3 3 3 3 3 3 3 3 5 5 5 5 5 5 0 0 0 0 0
0 0 0 0 0 0 0 0 0 0 2 2 2 2 2 3 3 3 3 3 5 5 5 5 5 5 0 0 0 0 0

El. Guit. 2
T A B
0 0 0 0 0 0 0 0 0 0 2 2 2 2 2 3 3 3 3 3 5 5 5 5 5 5 0 0 0 0 0
0 0 0 0 0 0 0 0 0 0 3 3 3 3 3 3 3 3 3 3 5 5 5 5 5 5 0 0 0 0 0
0 0 0 0 0 0 0 0 0 0 2 2 2 2 2 3 3 3 3 3 5 5 5 5 5 5 0 0 0 0 0

El. B.
T A B
0 0 0 0 0 0 0 0 0 0 2 2 2 2 2 3 3 3 3 3 5 5 5 5 5 5 0 0 0 0 0

95

Vo. E - den a - waits us - ,

El. Guit. 1 P.M. ----| P.M. ----| P.M. ----| P.M. ----|

El. Guit. 2 P.M. ----| P.M. ----| P.M. ----| P.M. ----|

El. B.

98

Vo. peace, still-ness and har - mo - ny, but a ques - tion a -

El. Guit. 1 P.M. ----| P.M. ----| P.M. ----| P.M. ----| P.M. ----| P.M. ----|

El. Guit. 2 P.M. ----| P.M. ----| P.M. ----| P.M. ----| P.M. ----| P.M. ----|

El. B.

101

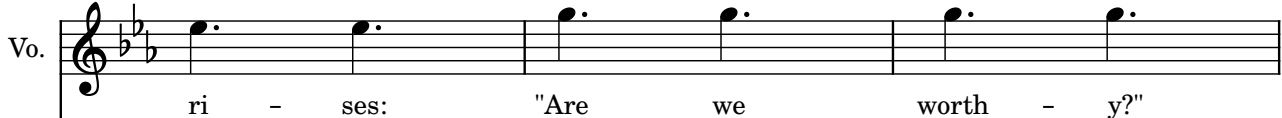
Vo. 

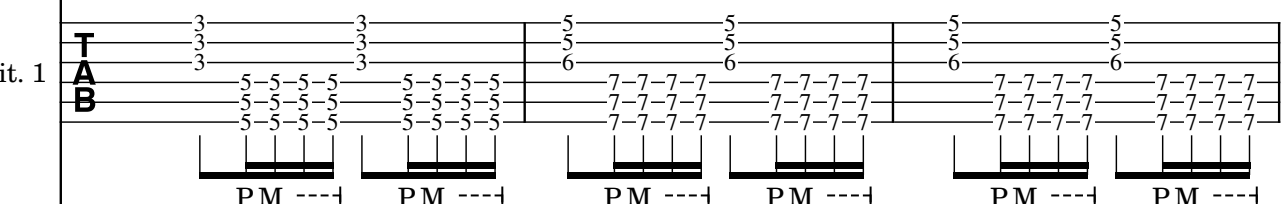
El. Guit. 1 

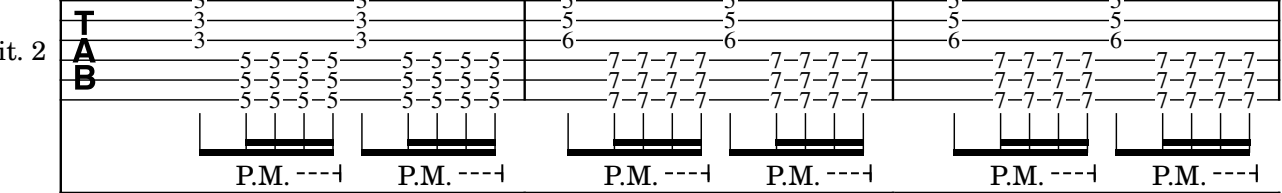
El. Guit. 2 

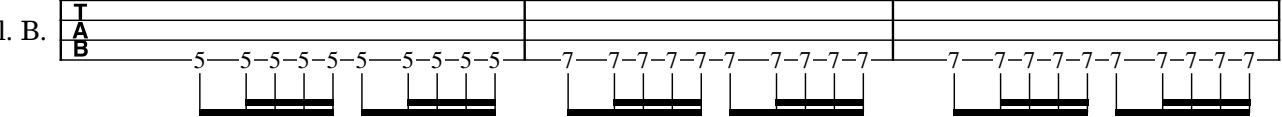
El. B. 

104

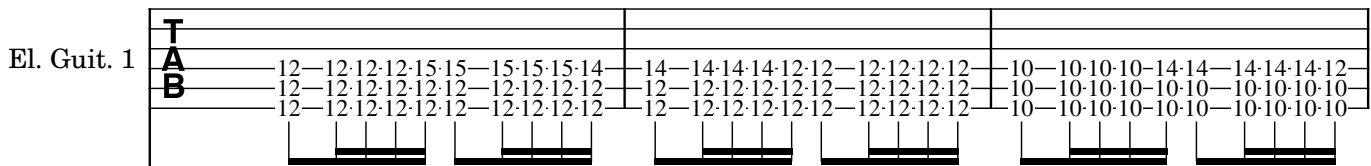
El. Guit. 1 

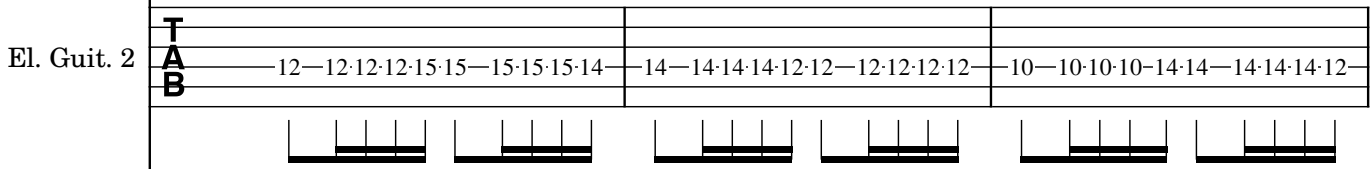
El. Guit. 2 

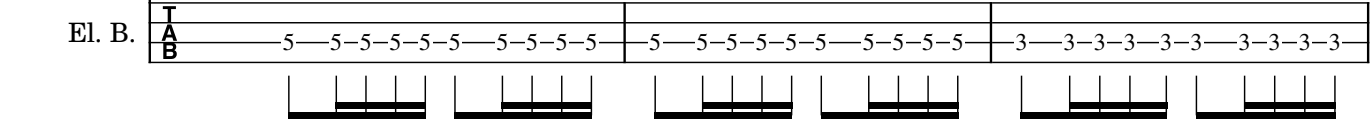
El. B. 

107

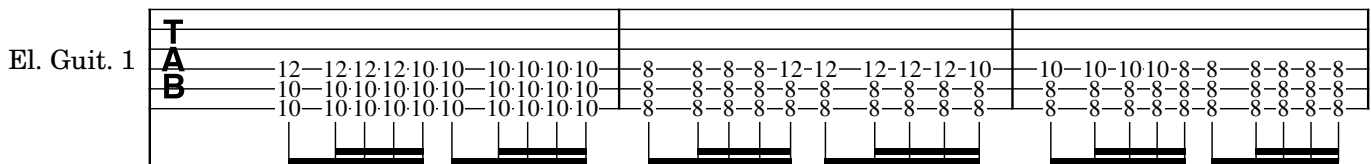
El. Guit. 1 

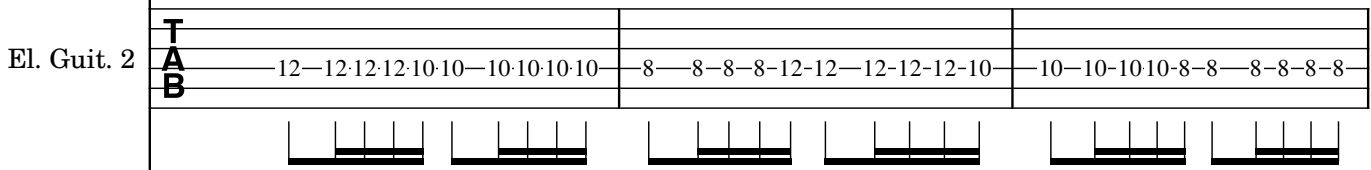
El. Guit. 2 

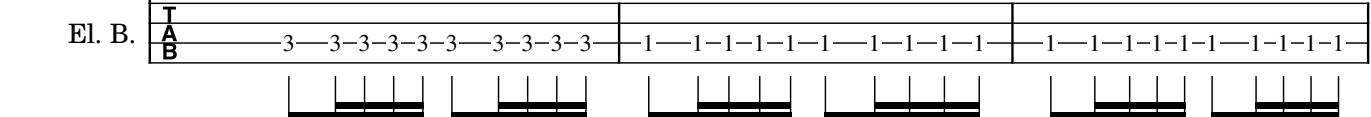
El. B. 

119

El. Guit. 1

TAB

0-0-0-0-0-0 3-2-0-0 0-0-0-0-0-0 3-2-0-0 0-0-0-0-0-0 3-2-0-0

P.M. P.M. P.M.

El. Guit. 2

TAB

0-0-0-0-0-0 3-2-0-0 0-0-0-0-0-0 3-2-0-0 0-0-0-0-0-0 3-2-0-0

P.M. P.M. P.M.

El. B.

TAB

0-0-0-0-0-0 3-2-0-0 0-0-0-0-0-0 3-2-0-0 0-0-0-0-0-0 3-2-0-0

122

Vo.

The es - sence

El. Guit. 1

TAB

5-5-5-5-5-3 3-3-3-3 3-3-3-3-2-2-2-2 0-0-0-0-0-0 0-0-0-0-0-0

P.M. P.M. P.M. P.M.

El. Guit. 2

TAB

3-3-3-3-3-2 2-2-2-2 2-2-2-2-0-0-0-0 0-0-0-0-0-0 0-0-0-0-0-0

P.M. P.M. P.M. P.M.

El. B.

TAB

5-5-5-5-5-3 3-3-3-3 3-3-3-3-2-2-2-2 0-0-0-0-0-0 0-0-0-0-0-0

125

Vo.

of wis-dom has-n't been found,

El. Guit. 1

TAB

2-2-2-2-2-3 3-3-3-3 5-5-5-5-5-5 5-5-5-5 3-3-3-3-3-2 2-2-2-2

3-3-3-3-3-3 3-3-3-3 5-5-5-5-5-5 5-5-5-5 3-3-3-3-3-3 3-3-3-3

2-2-2-2-2-3 3-3-3-3 5-5-5-5-5-5 5-5-5-5 3-3-3-3-3-2 2-3-2-2

El. Guit. 2

TAB

2-2-2-2-2-3 3-3-3-3 5-5-5-5-5-5 5-5-5-5 3-3-3-3-3-2 2-2-2-2

3-3-3-3-3-3 3-3-3-3 5-5-5-5-5-5 5-5-5-5 3-3-3-3-3-3 3-3-3-3

2-2-2-2-2-3 3-3-3-3 5-5-5-5-5-5 5-5-5-5 3-3-3-3-3-2 2-3-2-2

El. B.

TAB

2-2-2-2-2-3 3-3-3-3 5-5-5-5-5-5 5-5-5-5 3-3-3-3-3-2 2-3-2-2

128

Vo. yet it lies some - where in a mo-ment of

El. Guit. 1

El. Guit. 2

El. B.

131

Vo. time and life. We are res-pons - i-ble,

El. Guit. 1 P.M. ----+

El. Guit. 2 P.M. ----+

El. B.

134

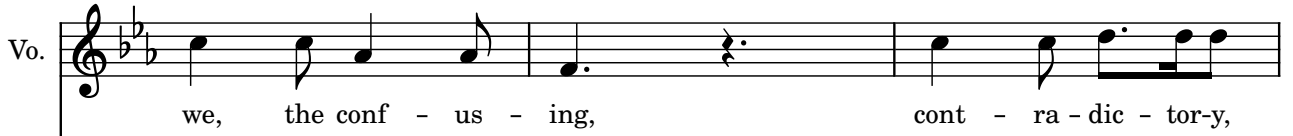
Vo. 

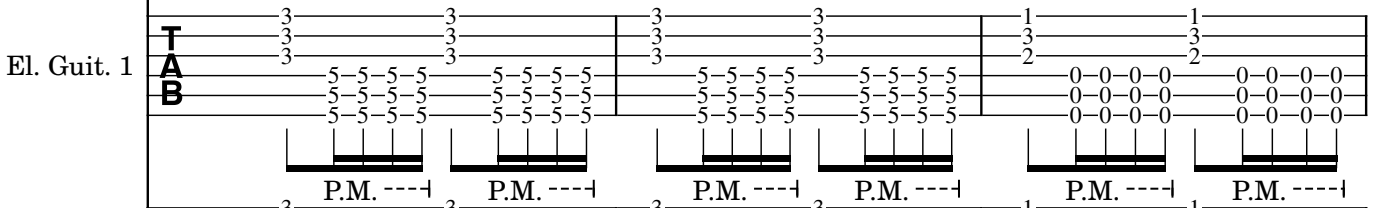
El. Guit. 1 

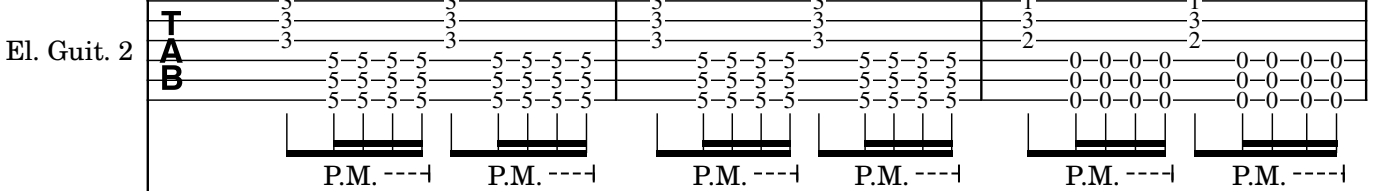
El. Guit. 2 

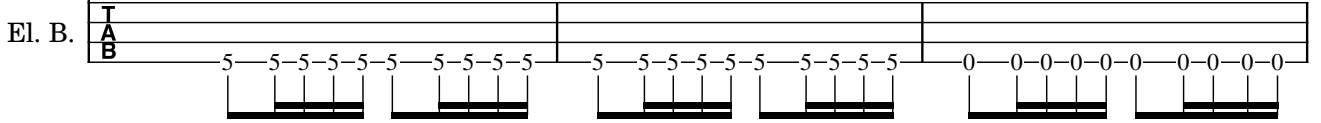
El. B. 

137

Vo. 

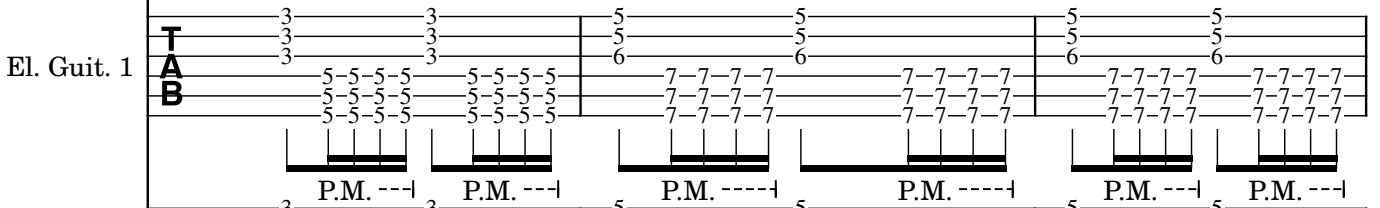
El. Guit. 1 

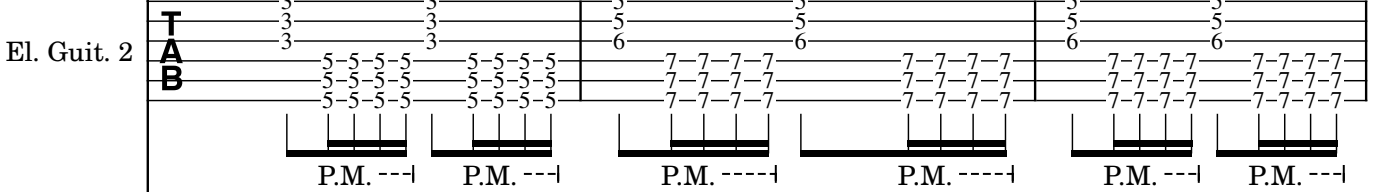
El. Guit. 2 

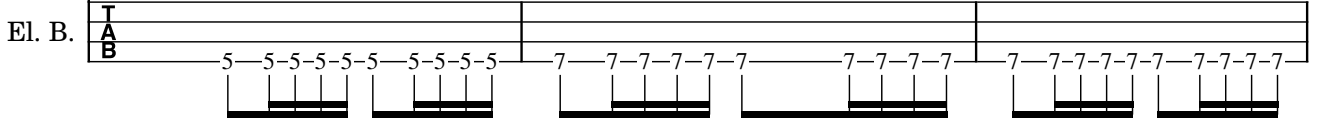
El. B. 

140

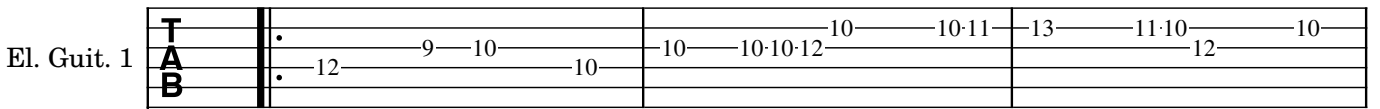
El. Guit. 1 

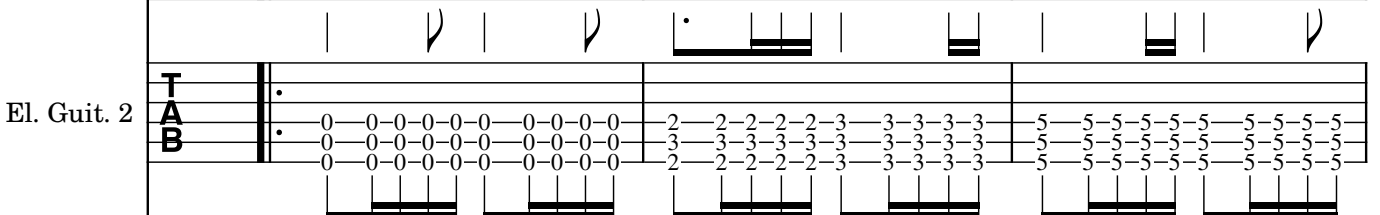
El. Guit. 2 

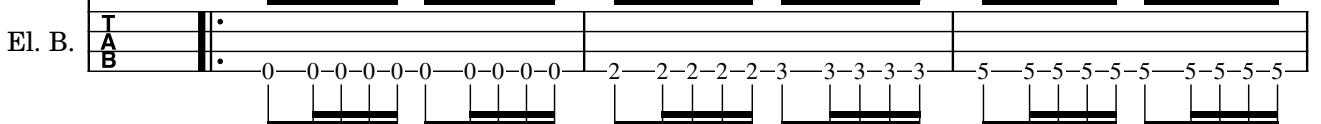
El. B. 

143

	1.	2.	
El. Guit. 1	T A B 11—10 12—9—10-9	T A B 11—10 12—9	0—0-0-0-0-0 3-2-0-0
El. Guit. 2	T A B 3—3-3-3-3-2 3—3-3-3-3-3 3—3-3-3-3-2	T A B 3—3-3-3-3-2 3—3-3-3-3-3 3—3-3-3-3-2	0—0-0-0-0-0 3-2-0-0
El. B.	T A B 3—3-3-3-3-2 2-3-2-2	T A B 3—3-3-3-3-2 2-3-2-2	0—0-0-0-0-0 3-2-0-0
			P.M. ----- P.M. ———

146

El. Guit. 1	T A B 0—0-0-0-0-0 3-2-0-0	0—0-0-0-0-0 3-2-0-0	0—0-0-0-0-0 3-2-0-0
El. Guit. 2	T A B 0—0-0-0-0-0 3-2-0-0	0—0-0-0-0-0 3-2-0-0	0—0-0-0-0-0 3-2-0-0
El. B.	T A B 0—0-0-0-0-0 3-2-0-0	0—0-0-0-0-0 3-2-0-0	0—0-0-0-0-0 3-2-0-0
			P.M. ----- P.M. ----- P.M. ----- P.M. -----

149

El. Guit. 1	T A B 5—5-5-5-5-3 3-3-3-3	3—3-3-3-3-2 2-2-2-2	0—0-0-0-0-0 3-2-0-0
El. Guit. 2	T A B 3—3-3-3-3-2 2-2-2-2	2—2-2-2-2-0 0-0-0-0	0—0-0-0-0-0 3-2-0-0
El. B.	T A B 5—5-5-5-5-3 3-3-3-3	3—3-3-3-3-2 2-2-2-2	0—0-0-0-0-0 3-2-0-0
			P.M. ----- P.M. ----- P.M. ----- P.M. ----- P.M. ----- P.M. -----

152

El. Guit. 1

TAB 0-0-0-0-0-0 3-2-0-0 0-0-0-0-0-0 3-2-0-0 0-0-0-0-0-0 3-2-0-0

P.M. P.M. P.M.

El. Guit. 2

TAB 0-0-0-0-0-0 3-2-0-0 0-0-0-0-0-0 3-2-0-0 0-0-0-0-0-0 3-2-0-0

P.M. P.M. P.M.

El. B.

TAB 0-0-0-0-0-0 3-2-0-0 0-0-0-0-0-0 3-2-0-0 0-0-0-0-0-0 3-2-0-0

155

Vo.

The es - sence

El. Guit. 1

TAB 5-5-5-5-5-3 3-3-3-3 3-3-3-3-2-2-2-2 0-0-0-0-0-0 0-0-0-0

P.M. P.M. P.M. P.M.

El. Guit. 2

TAB 3-3-3-3-3-2 2-2-2-2 2-2-2-2-0-0-0-0 0-0-0-0 0-0-0-0

P.M. P.M. P.M. P.M.

El. B.

TAB 5-5-5-5-5-3 3-3-3-3 3-3-3-3-2-2-2-2 0-0-0-0-0-0 0-0-0-0

158

Vo.

of life is in the deep green for - ests,

El. Guit. 1

TAB 2-2-2-2-2-3 3-3-3-3 5-5-5-5-5-5 5-5-5-5 3-3-3-3-2 2-2-2-2

3-3-3-3-3-3 3-3-3-3 5-5-5-5-5-5 5-5-5-5 3-3-3-3-3 3-3-3-3

2-2-2-2-2-3 3-3-3-3 5-5-5-5-5-5 5-5-5-5 3-3-3-3-2 2-3-2-2

El. Guit. 2

TAB 2-2-2-2-2-3 3-3-3-3 5-5-5-5-5-5 5-5-5-5 3-3-3-3-2 2-2-2-2

3-3-3-3-3-3 3-3-3-3 5-5-5-5-5-5 5-5-5-5 3-3-3-3-3 3-3-3-3

2-2-2-2-2-3 3-3-3-3 5-5-5-5-5-5 5-5-5-5 3-3-3-3-2 2-3-2-2

El. B.

TAB 2-2-2-2-2-3 3-3-3-3 5-5-5-5-5-5 5-5-5-5 3-3-3-3-2 2-3-2-2

161

Vo.  on the cold end - less gla - ci-ers, in the depths of

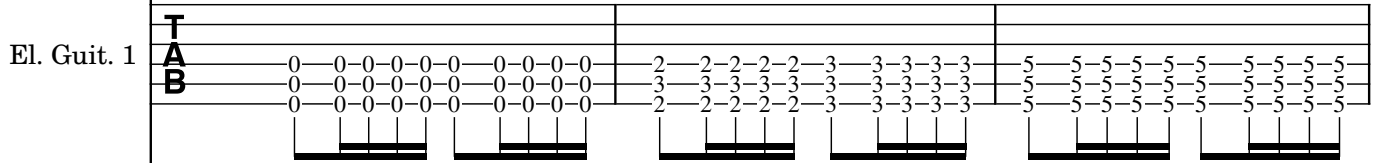
El. Guit. 1 

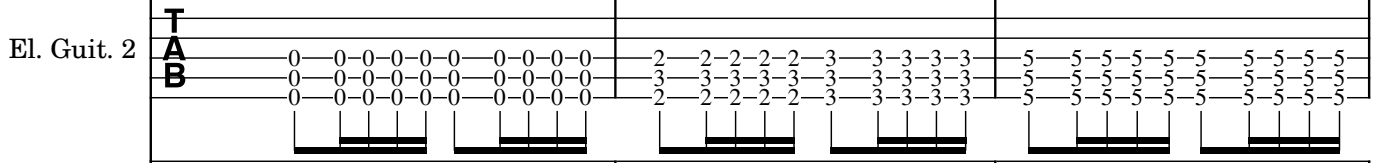
El. Guit. 2 

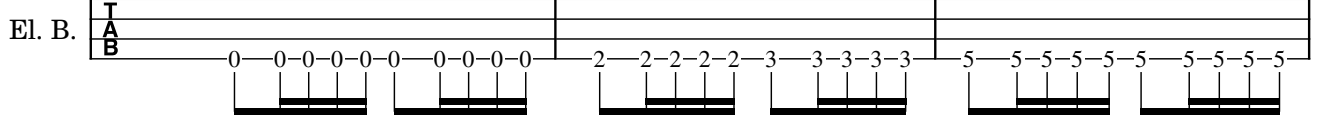
El. B. 

164

Vo.  oce - ans. The es-sence of u - ni-verse

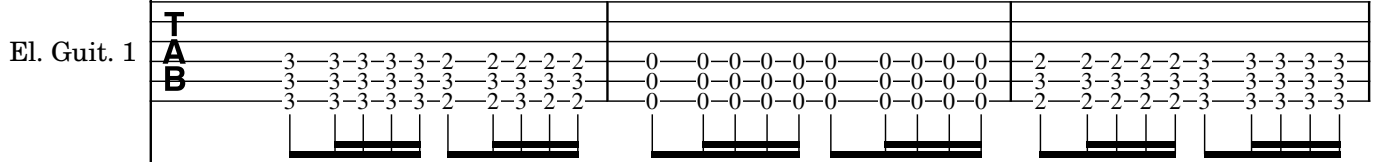
El. Guit. 1 

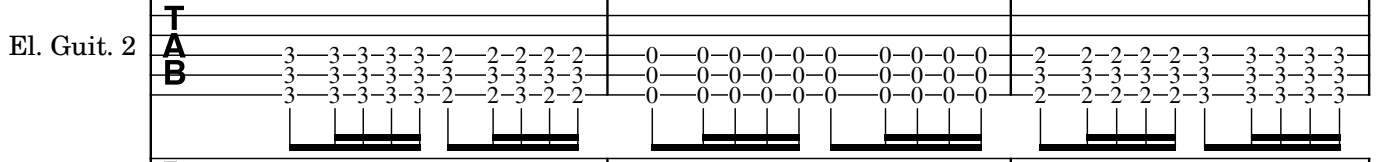
El. Guit. 2 

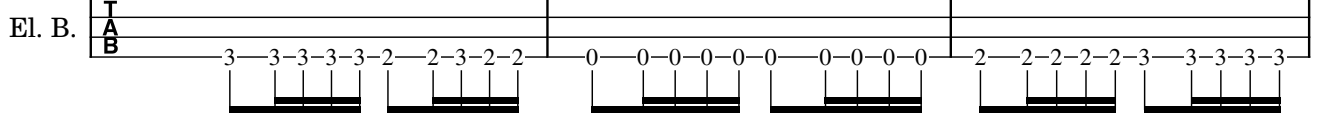
El. B. 

167

Vo.  is re-volv-ing a - round the al-might - y

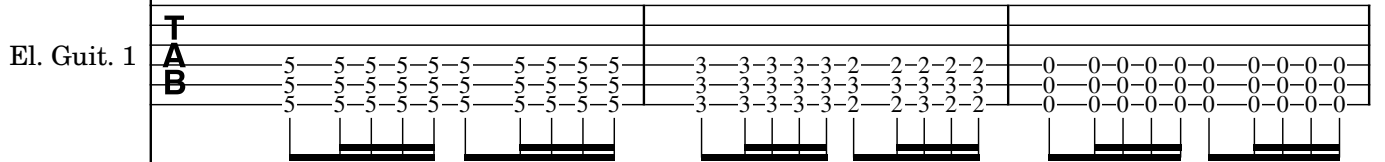
El. Guit. 1 

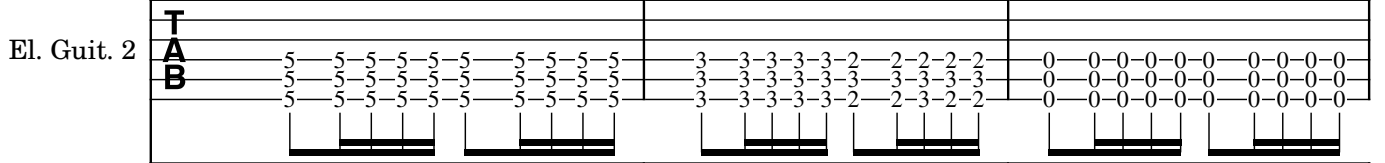
El. Guit. 2 

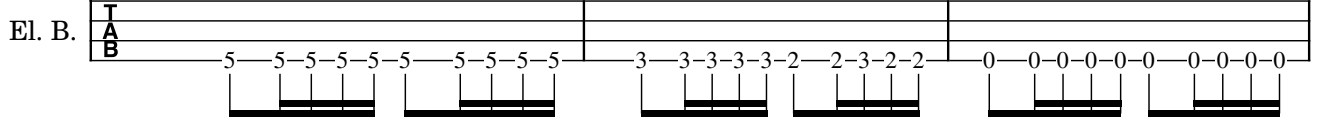
El. B. 

170

Vo. 

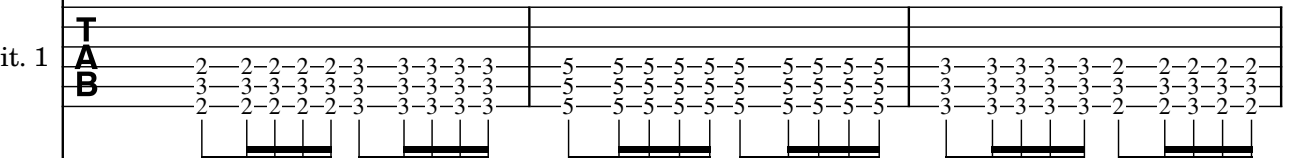
El. Guit. 1 

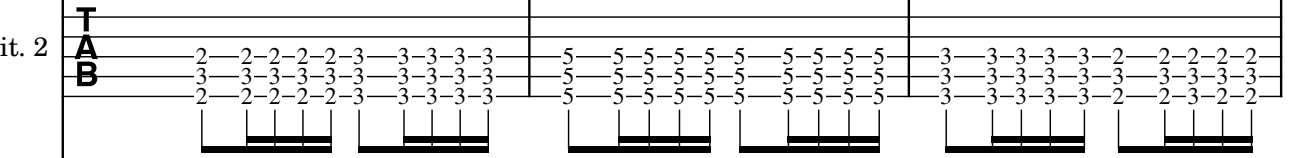
El. Guit. 2 

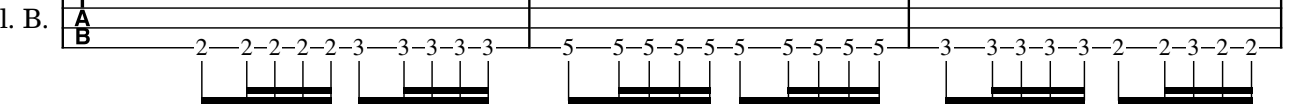
El. B. 

173

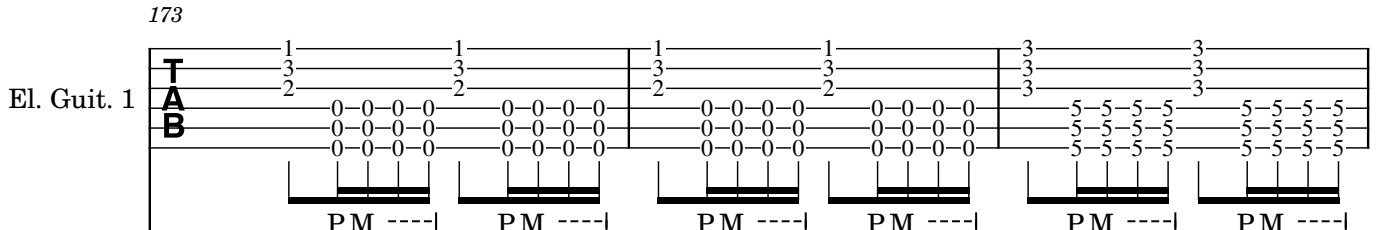
El. Guit. 1 

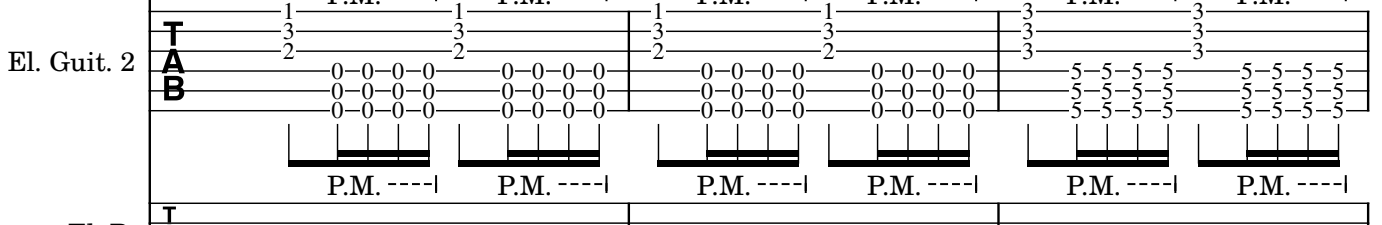
El. Guit. 2 

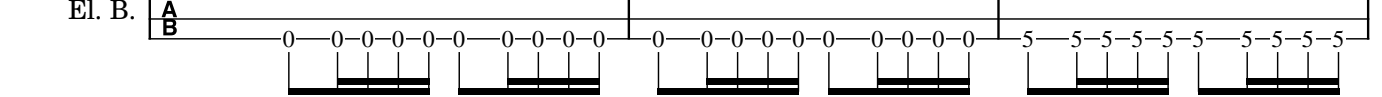
El. B. 

176

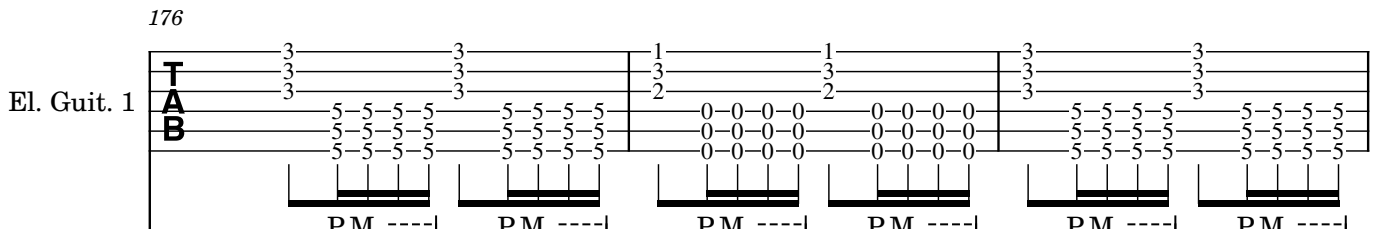
El. Guit. 1 

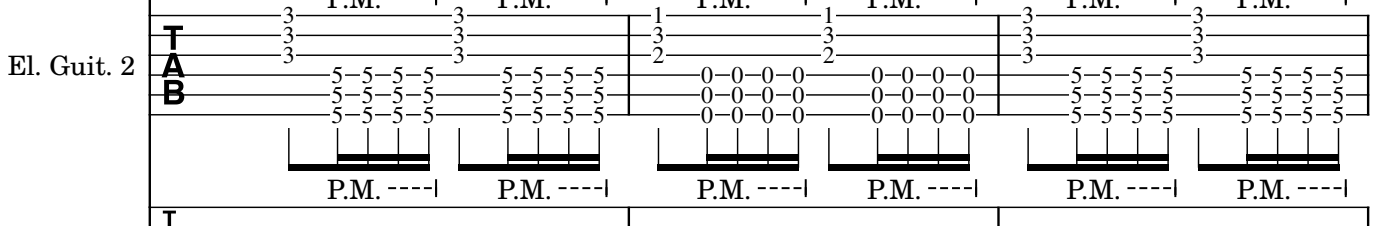
El. Guit. 2 

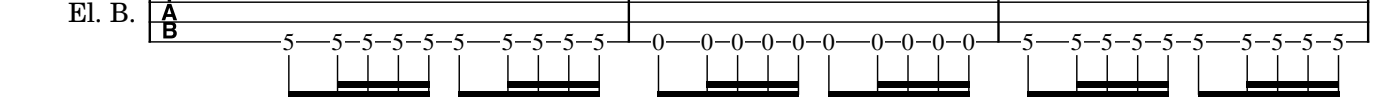
El. B. 

179

$\text{♩} = 85$

El. Guit. 1

El. Guit. 2

El. B.

184

rit. $\text{♩} = 90$

El. Guit. 1

El. Guit. 2

El. B.

188

El. Guit. 1

El. Guit. 2

El. B.

191

El. Guit. 1
TAB 5-5-5-5-5-3-3-3-3-3 3-3-3-3-3-2-2-2-2-2 0-0-0-0-0-0-0 3-2-0-0
P.M. ----| P.M. ----| P.M. ----| P.M. ----| P.M. -----| P.M. ----

El. Guit. 2
TAB 3-3-3-3-3-2-2-2-2-2 2-2-2-2-2-0-0-0-0-0 0-0-0-0-0-0-0 3-2-0-0
P.M. ----| P.M. ----| P.M. ----| P.M. ----| P.M. -----| P.M. ----

El. B.
TAB 5-5-5-5-5-3-3-3-3-3 3-3-3-3-3-2-2-2-2-2 0-0-0-0-0-0-0 3-2-0-0
P.M. ----| P.M. ----| P.M. ----| P.M. ----| P.M. -----| P.M. ----

194

El. Guit. 1
TAB 0-0-0-0-0-0-0 3-2-0-0 0-0-0-0-0-0 3-2-0-0 0-0-0-0-0-0 3-2-0-0
P.M. -----| P.M. -----| P.M. -----| P.M. ----|

El. Guit. 2
TAB 0-0-0-0-0-0-0 3-2-0-0 0-0-0-0-0-0 3-2-0-0 0-0-0-0-0-0 3-2-0-0
P.M. -----| P.M. -----| P.M. -----| P.M. ----|

El. B.
TAB 0-0-0-0-0-0-0 3-2-0-0 0-0-0-0-0-0 3-2-0-0 0-0-0-0-0-0 3-2-0-0
P.M. -----| P.M. -----| P.M. -----| P.M. ----|

197

Vo.
E - den will be

El. Guit. 1
TAB 5-5-5-5-5-3-3-3-3-3 3-3-3-3-3-2-2-2-2-2 0-0-0-0-0-0-0 0-0-0-0-0-0-0
P.M. ----| P.M. ----| P.M. ----| P.M. ----|

El. Guit. 2
TAB 3-3-3-3-3-2-2-2-2-2 2-2-2-2-2-0-0-0-0-0 0-0-0-0-0-0-0 0-0-0-0-0-0-0
P.M. ----| P.M. ----| P.M. ----| P.M. ----|

El. B.
TAB 5-5-5-5-5-3-3-3-3-3 3-3-3-3-3-2-2-2-2-2 0-0-0-0-0-0-0 0-0-0-0-0-0-0
P.M. ----| P.M. ----| P.M. ----| P.M. ----|

200

Vo. 

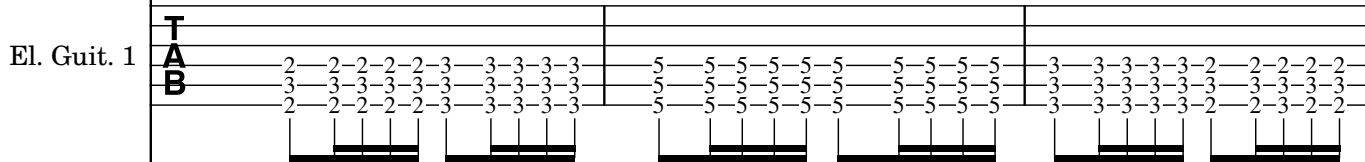
El. Guit. 1 

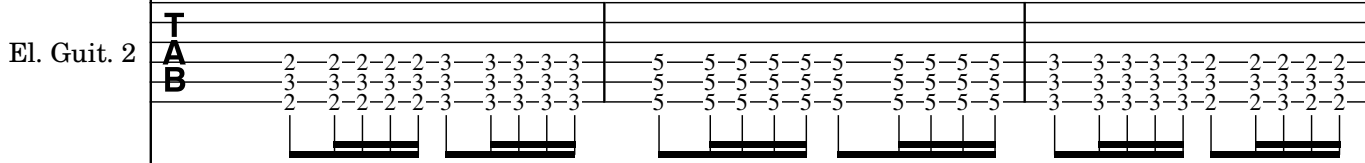
El. Guit. 2 

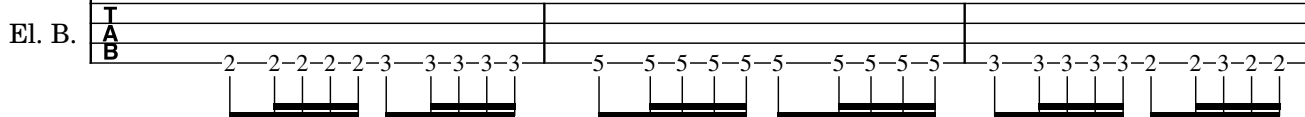
El. B. 

203

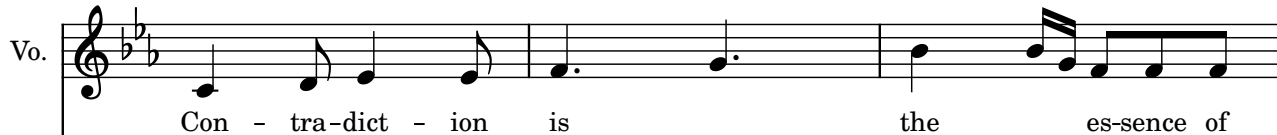
Vo. 

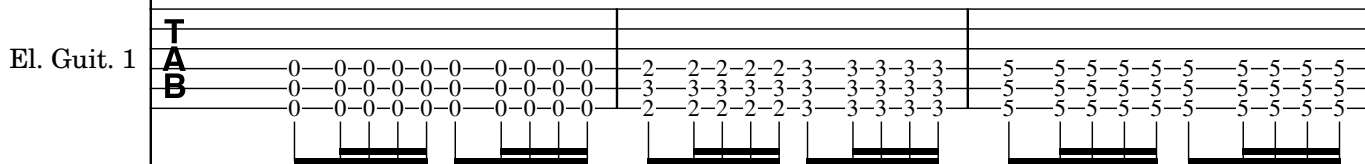
El. Guit. 1 

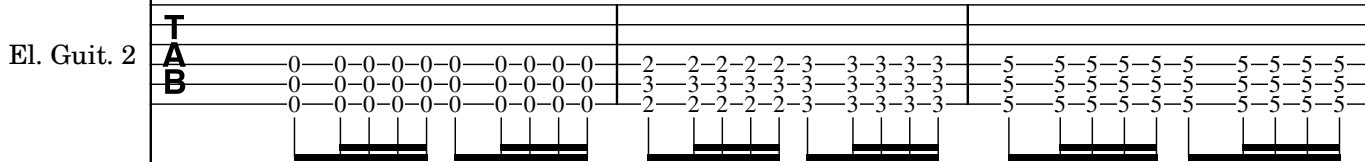
El. Guit. 2 

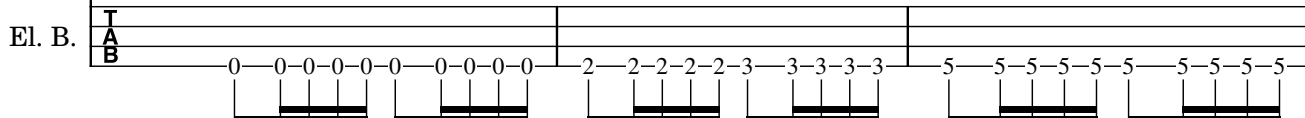
El. B. 

206

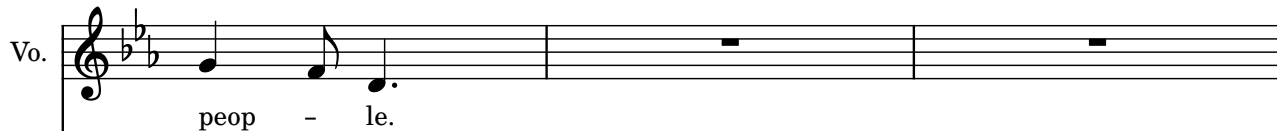
Vo. 

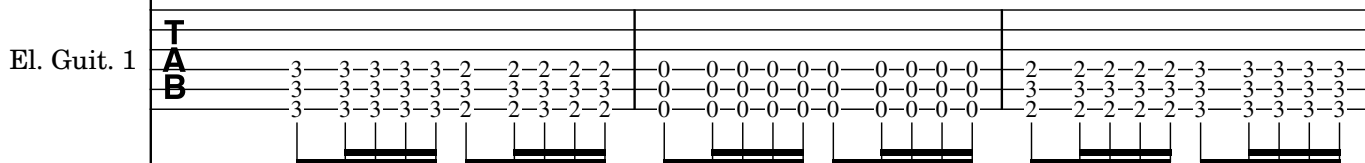
El. Guit. 1 

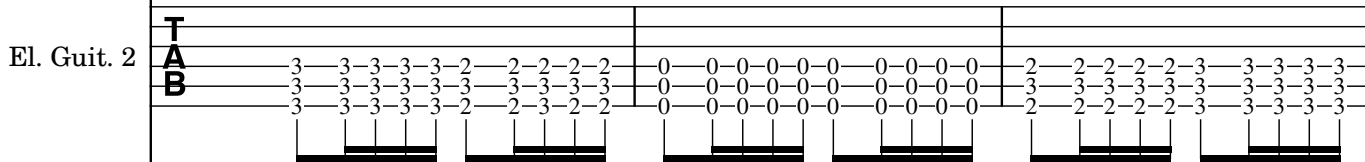
El. Guit. 2 

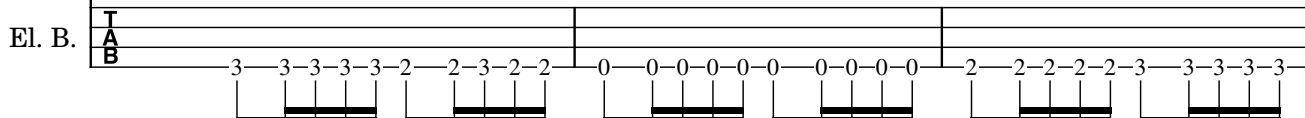
El. B. 

209

El. Guit. 1
T
A
B
5 5 5 5 5 5 5 5 5 5 3 3 3 3 3 2 2 2 2 2 0 0 0 0 0 0 0 0 0 0
5 5 5 5 5 5 5 5 5 5 3 3 3 3 3 3 3 3 3 3 0 0 0 0 0 0 0 0 0 0
5 5 5 5 5 5 5 5 5 5 3 3 3 3 3 2 2 3 2 2 0 0 0 0 0 0 0 0 0 0

El. Guit. 2
T
A
B
5 5 5 5 5 5 5 5 5 5 3 3 3 3 3 2 2 2 2 2 0 0 0 0 0 0 0 0 0 0
5 5 5 5 5 5 5 5 5 5 3 3 3 3 3 3 3 3 3 3 0 0 0 0 0 0 0 0 0 0
5 5 5 5 5 5 5 5 5 5 3 3 3 3 3 2 2 3 2 2 0 0 0 0 0 0 0 0 0 0

El. B.
T
A
B
5 5 5 5 5 5 5 5 5 5 3 3 3 3 3 2 2 3 2 2 0 0 0 0 0 0 0 0 0 0

212

El. Guit. 1
T
A
B
2 2 2 2 2 3 3 3 3 3 5 5 5 5 5 5 5 5 3 3 3 3 2 2 2 2 10 10
3 3 3 3 3 3 3 3 3 3 5 5 5 5 5 5 5 5 3 3 3 3 3 3 2 2 2 2 10 10
2 2 2 2 2 3 3 3 3 3 5 5 5 5 5 5 5 5 3 3 3 3 3 2 2 3 2 2 0 0
|• |•

El. Guit. 2
T
A
B
2 2 2 2 2 3 3 3 3 3 5 5 5 5 5 5 5 5 3 3 3 3 2 2 2 2 10 10
3 3 3 3 3 3 3 3 3 3 5 5 5 5 5 5 5 5 3 3 3 3 3 3 3 3 2 2 2 2 10 10
2 2 2 2 2 3 3 3 3 3 5 5 5 5 5 5 5 5 3 3 3 3 3 2 2 3 2 2 0 0
|• |•

El. B.
T
A
B
2 2 2 2 2 3 3 3 3 3 5 5 5 5 5 5 5 5 3 3 3 3 2 2 3 2 2 0 0
|• |•

217

El. Guit. 1
T
A
B
10 10 10 0 0
|• |•

El. Guit. 2
T
A
B
10 10 10 0 0
|• |•

El. B.
T
A
B
0 0
|• |•